

JUNG PUMPEN U5K DRAINAGE PUMPS

APPLICATION

The U 5 K (S) is an extremely powerful and versatile centrifugal submersible pump for both stationary and portable use. The pump is suitable for faecal-free wastewater with solids up to 10 mm particle size. Thanks to the removable strainer base, it is possible to increase the free passage to 20 mm.

Stationary in a basement chamber or a collecting tank, with an automatic switch attached, the U 5 KS handles all dirty water arising from domestic drainage sources such as washing machines, dishwashers, washstands, etc. Deposit accumulation in the reservoirs and chambers is reduced to a minimum by means of a flushing device.

The guide rail system GR 32 offers all the advantages of fast and easy maintenance. If the sump or tank runs dry temporarily, the pump can be vented by providing a drill-hole in the spiral housing.

The U 5 K can be used as a portable unit for dealing with dirty water from garden ponds, flooded cellars or discharge chambers in laundry rooms or storage rooms. Thanks to its shallow, built-in suction system, it can reduce residual water level to no more than a few millimeters.

If submersible pumps are used outdoors, only a pump with 10 m cable without extension cable may be used in accordance with VDE Regulation 0100. For construction sites and garden ponds, a H07-type cable must be used.

- Continuous operation
- Low level pumping
- Flushing device
- Built-in level control
- Variable discharge branch
- Safe to run dry
- 10/20 mm free passage with EIP technology
- Swing-type check valve for portable use
- Moisture sealed cable inlet



U 5 KS with built-in level control

PERFORMANCE

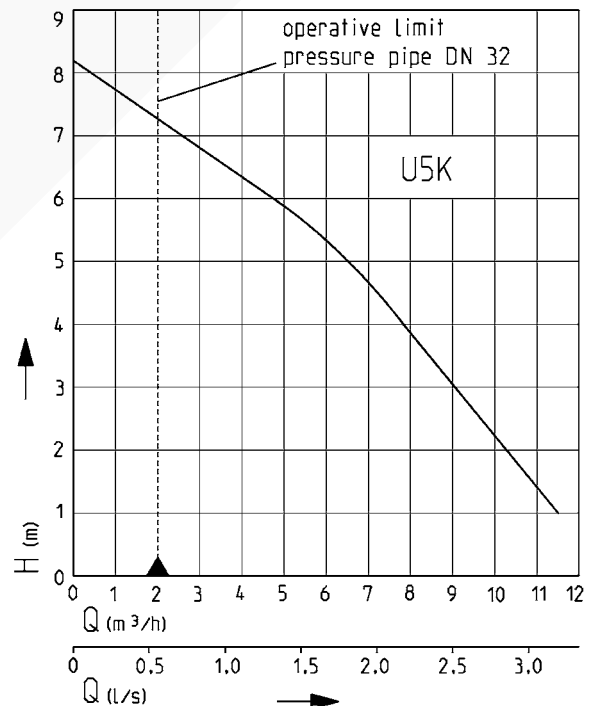

40895-01

We reserve the right to change specifications without notice

Pump performance is subject to ISO 9906 tolerances

The minimum flow velocity in the pressure piping must be 0.7 m/s according to EN 12056.

This data is represented in the performance curve as a limit of application.

JUNG PUMPEN U5K

DRAINAGE PUMPS

DRAINAGE PUMPS

Type		Maximum Height x Width x Depth	Discharge branch	Free passage	Cable quality	Cable length	Weight approx.	Code No.
Pump without level control (not to be utilised on construction sites, as per VDE regulations)								
U5K	without bend	280 x 168 x 190 mm	1½"	20 mm	H05RN-F-3G0.75	10 m	4.7 kg	JP09386
	with bend	280 x 168 x 250 mm						
Pumps with built-in level control								
U5KS	(acc. to VDE, not to be used outdoors)	280 x 202 x 290 mm	1½"	20 mm	H05RN-F-3G0.75	3 m	4.5 kg	JP09387
U5KS		280 x 202 x 290 mm	1½"	20 mm	H07RN-F-3G1.00	10 m	5.4 kg	JP09417

PERFORMANCE

Type	Delivery head H [m]	1	2	3	4	5	6	7
U5K	Flow rate Q [m³/h]	11.5	10.5	9	7.5	6.5	4.5	2.5

ELECTRICAL DATA

Type	Type of current	Voltage Volt	Motor rating kW		RPM min ⁻¹	Current Ampere	Motor protection	Plug
			P ₁	P ₂				
U5K	W-Current	1/N/PE~230	0.52	0.38	2716	2.3	integrated	Safety-

Example of single pump installation with GR

Single unit with built-in level control
 Sump area with GR 32 min. 40 x 50 cm, Ø 50 cm
 Sump area without GR min. 40 x 40 cm, Ø 40 cm (without ill.)

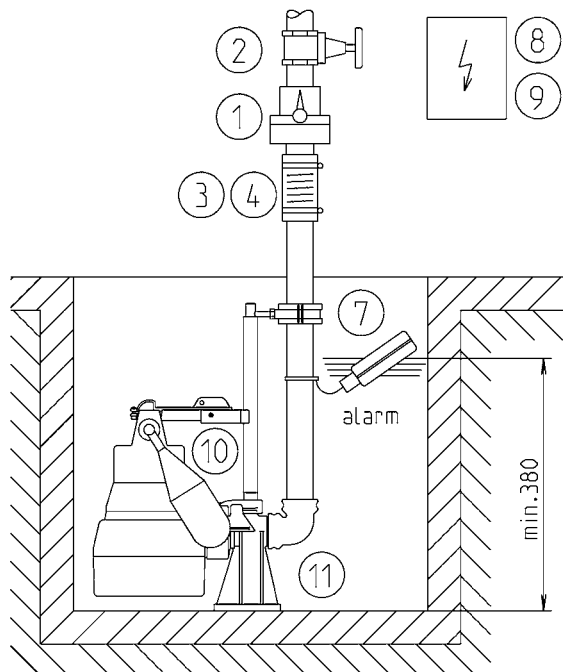

40522-02

In case of installation beneath the backpressure level the pressure tube must be taken in a loop over the local backup level acc. to EN 12056. Besides, it must be secured with a EN 12050-4-proofed swing-type check valve. Besides, it must be secured with an EN 12050-4-proofed swing-type check valve. Additionally we recommend an alarm system.

Example of duplex pump installation

Duplex unit with control unit
 Sump area with GR 32 min. 50 x 50 cm, Ø 60 cm (without ill.)
 Sump area without GR min. 45 x 50 cm, Ø 55 cm

Suspend control unit in a dry room.

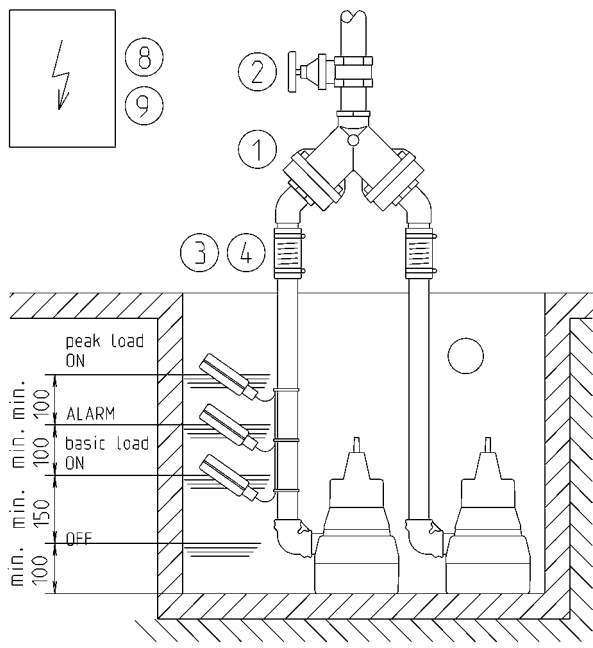

↑ Notice of min. distance !

40521-01

In accordance with DIN EN 12056-4 Abs. 5.1, it has a built-in automatic spare pump or a double attachment included, which ensures that sewage drainage is not interrupted.

JUNG PUMPEN U5K

DRAINAGE PUMPS

TECHNICAL DATA

Pump

Vertical, single-stage, submersible, foot strainer with 10 mm free passage – detachable for activating low level pumping. With the pump base installed, free passage is 20 mm. Volute casing with 1 1/4" male radial pressure branch, EIP-technology hydraulics with open 5-blade impeller.

Bearings

Common shaft for pump and motor, mounted in ball bearings and permanently grease lubricated.

Seal

A shaft seal, which is completely secure against running dry thanks to a three-fold radial shaft seal ring and intermediate oil chamber.

Motor

Submersible motor, type of enclosure IP 68, insulation class B, motor thermostat for emergency switch-off on overheating with automatic switch-on after sufficient cooling, switched on via plug or automatic switching, moisture sealed cable inlet for protecting the pump in the event of damage to the cable, continuous operation when not submerged on account of its motor jacket cooling.

Material

Motor housing, shaft and screws in stainless steel, volute casing, impeller and control head in plastic (GRP), rubber insulated sewage resistant flexible cable.

Installation

Install pump vertically (hoose connection possible); if installed permanently, provide detachable connection, e.g. the uncomplicated and easy to maintain guide rail system GR 32.

Scope of supply

Pump ready for connection acc. to EN 12050 with 90°, 1 1/4" female connection elbow, cable and safety plug, S model with automatic level float switch.

The pump is delivered fitted with a strainer base which can be swapped for any of the accompanying pedestals in cases where a 20 mm clear passage is required.

